

Thunder Scientific Corporation



Model 3920

*“Two-Pressure Two-Temperature”
Low Humidity Generator*

Model 3920

Low Humidity Generation System

FEATURES

- Traceable to SI¹
- Based on NIST “Two-Pressure” Principle
- High Flow Capability of 10 L/min
- ControLog[®] Embedded Automation Software
- Generate: Frost Point, Dew Point, PPM, %RH
- HumiCalc[®] Mathematical Engine
- Calculated Real-Time Uncertainty
- Calculated Water Capacity / Usage
- Ability to Operate Using External Computer
- VCR[®] Metal Gasket Face Seal Fittings
- Diaphragm-sealed Control Valves
- 10.1” Multi-Point Touch LCD

DESCRIPTION

The 3920 Low Humidity Generation System is a self-contained system capable of producing atmospheres of known humidity utilizing the fundamental NIST-proven “two-pressure” “two-temperature” humidity generation principles. This system is capable of continuously supplying frost point, dew point, parts per million, relative humidity and other calculated values for instrument calibration and evaluation as well as for precision environmental testing. This system will automatically generate manually entered humidity setpoints as well as user created multipoint profiles. Visual indications of system status are displayed in real time on the computer monitor.

PRINCIPLE OF OPERATION

The humidity generation process involves saturating nitrogen or CO₂ free air with water vapor at a known temperature and pressure. The saturated gas is then reduced to test pressure and warmed to test temperature. The measurements of saturation temperature, saturation pressure, test temperature, and test pressure are used in the determination of all hygrometric parameters. System precision is determined by the accuracy and stability of the temperature and pressure measurements. The system does not use or rely on the measurement of water vapor content for calculation or control.

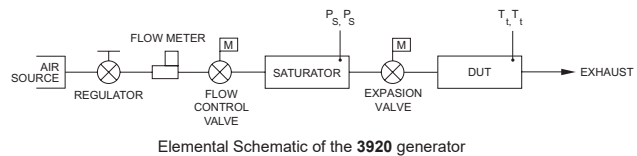

CONTROL/COMPUTER SYSTEM

The 3920 Low Humidity Generation System encompasses a high-performance stand-alone Control System that performs all functions required for humidity generation and control. The Control System employs 24 bit I/O modules with integrated signal conditioning to acquire analog data, serial interfaces to acquire digital data from the transducers, and digital stepper motor actuated diaphragm valves to control the operation of generating humidity. The Control System utilizes an embedded operating system in conjunction with specialty software to control and interface with the human to machine interface (HMI) computer that runs ControLog[®].

ControLog is an embedded software application that fully automates the operation of the 3920 Low Humidity Generation System and allows various device connections through a number of different interfaces. ControLog uses Thunder Scientific's HumiCalc with Uncertainty[®] as its mathematical engine for computing all humidity values and real-time uncertainties. Data from the generator and attached devices is automatically retrieved and stored for viewing in either numerical or graphical format in real time or post process.

Data can be transferred off the system via a USB drive for further viewing, post processing and printing using an external Windows PC. The ControLog software also provides the primary interface to the operator via the multi-point touch display. The main panel has easy access to the keyboard allowing the user to input data directly without connecting an external PC.

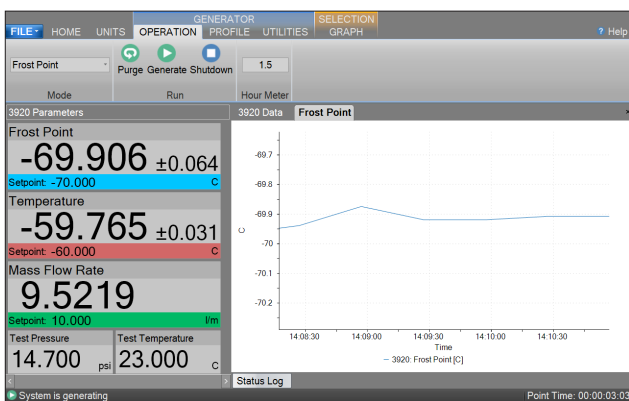
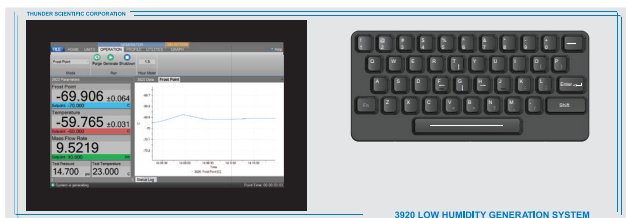

The Water Capacity dialog allows the user to view the current estimated water remaining in the generator and allows the user to perform clear cycles after filling.

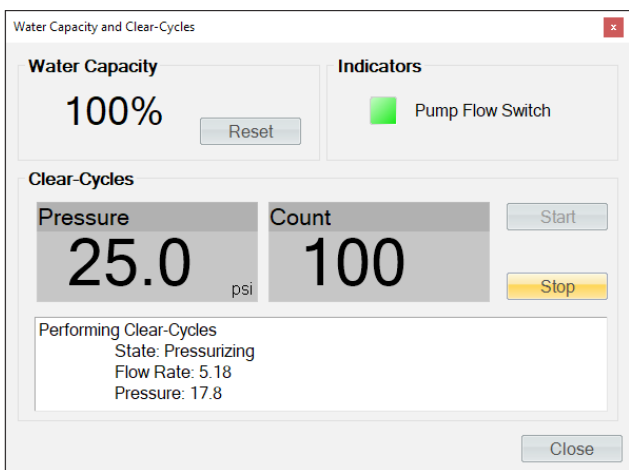

An external Windows PC can also be connected via an RS-232 connection to run a desktop version of ControLog. The desktop version has the same functionality as the embedded version but runs on a stand-alone Windows PC (not included). This allows the user to operate the software with larger displays or on specific computer networks to aid in file saving and transfer.

During desktop operation the embedded version locks out user setpoint changes but still allows data viewing and graphing.

Temperature Control: Temperature setpoint control is attained by controlling the temperature of a circulating fluid medium that jackets the saturator of the generator. The saturation temperature is governed by the temperature of this medium, which is digitally controlled by the computer at any value between $-80\text{ }^{\circ}\text{C}$ and $12\text{ }^{\circ}\text{C}$ through the use of PID (proportional-integral-derivative) algorithms.

Pressure and Flow Control: Saturation pressure control and mass flow control is accomplished through computer actuation of electromechanical diaphragm sealed valve assemblies. Saturation pressure and mass flow are measured continuously and controlled using PID algorithms similar to those employed in temperature control. All fittings in the humidity generating path are VCR[®] Metal Gasket Face Seals and all valves in the humidity generating path are diaphragm-sealed for reduced water vapor permeation. All interconnect tubing is electro-polished 316 stainless steel.

Calibration: Proper calibration of the temperature and pressure transducers ultimately determines the uncertainty of the generator. This system employs an integral programmatic calibration scheme allowing the transducers to be calibrated while they are electrically connected to the humidity generator.

APPLICATIONS

Chilled Mirror Hygrometers: Connecting the generator output to a chilled mirror hygrometer allows the user to verify the mirror temperature measurement accuracy; perform operational checks on the hygrometer components; determine whether the hygrometer is controlling the mirror in the liquid phase or ice phase when operating below $0\text{ }^{\circ}\text{C}$; determine if the hygrometer is correctly calculating other humidity parameters; determine hygrometer repeatability, stability, and drift characteristics.

Humidity Sensors and Electrolytic Hygrometers: Connecting the generator output to special fixtures, hygrometer sampling systems, or individual sensors allows the user to calibrate and/or characterize humidity sensitivity; perform operational checks such as the sensing systems capability to correctly calculate and display other humidity parameters; determine repeatability, stability, hysteresis and/or drift characteristics of various humidity sensing systems.

Environmental Testing: The 3920 can serve as a test bed for evaluation and R&D of humidity sensors, humidity sensing systems, and humidity sensitive products, e.g., polymers, composites, film, magnetic medium, pharmaceuticals, soil hydrology, consumables, electronics, optics, etc.

Model 3920

Low Humidity Generation System

SPECIFICATIONS²

Frost Point Temperature Range:	-95 to 0.01 °C
Dew Point Temperature Range:	-50 to 10 °C
Parts Per Million Range:	0.04 to 12300 PPMv
Relative Humidity Range:	0.00003% to ~50%
Saturation Temperature Range: ³	-80 to 12 °C
Saturation Temperature Control Stability: ⁴	0.008 °C
Saturation Temperature Cooling Rate: from 12 to -80 °C	0.33 °C per Minute (average)
Saturation Temperature Heating Rate: from -80 to 12 °C	0.33 °C per Minute (average)
Test Temperature Range (measured):	0 to 50 °C
Saturation Pressure Range:	~Ambient to 250 psiA
Saturation Pressure Specification:	0.02% of full scale
Test Pressure Range (measured):	Ambient to 50 psiA
Test Pressure Specification:	0.02% of full scale
Gas Type:	Gaseous Nitrogen or CO ₂ free Air
Supply Pressure Range:	80 to 300 psiG
Supply Pressure Specification:	±1.25 psiG
Gas Flow Rate Range:	0.5 to 10 SLPM
Gas Flow Rate Specification:	2% of full scale
Display Resolution:	0.001
Refrigeration:	1/3 HP R-134A & 1/3 HP R-23 in cascade
Heating:	Stainless Steel Immersion
Test Port & Gas Inlet:	1/4 Inch Swagelok VCR®
Physical Dimensions:	38" H x 23" W x 35" D (965.2 mm x 584.2 mm x 889 mm)

UNCERTAINTY^{2,5,6}

Dew Point Uncertainty: -50 °C to 10 °C	0.01% R + 0.07 °C
Frost Point Uncertainty: ≥ -90 °C	0.05% R + 0.07 °C
Frost Point Uncertainty: < -90 °C	1.7% R - 1.45 °C
Test Temperature Uncertainty: 0 to 50 °C	0.031 °C

UTILITIES

Electrical Power:	220/230 V~, 10 A, 1 Ø, 50/60 Hz
Gas Supply:	80 psiG to 300 psiG @ 10 L/min
Floor Space:	9 ft ² (0.84 m ²)

ENVIRONMENTAL

Operating Temperature:	15 to 30 °C
Storage Temperature:	0 to 50 °C
Humidity:	5 to 95% RH Non-condensing

¹ Traceable to the International System of Units (SI) through a national metrology institute (NIST) recognized through a CIPM MRA.

² Test pressure at 1 atmosphere.

³ Using anhydrous methanol as the temperature heat transfer fluid from -80 to 12 °C.

⁴ Temperature Control Stability is defined as the standard deviation over a 10-minute period, as measured by the saturation temperature control sensor after being at point for 60 minutes.

⁵ Uncertainty values represent an expanded uncertainty using a coverage factor, k=2, at an approximate level of confidence of 95%.

⁶ Uncertainty is based on the worst-case value from the 3920 uncertainty analysis.

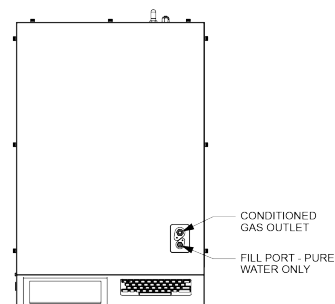

TOP VIEW

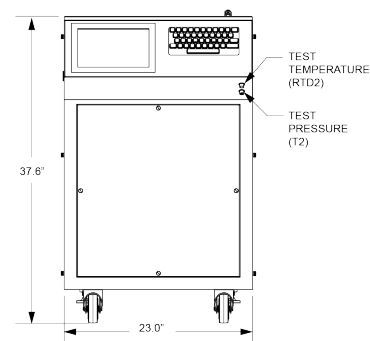

FRONT VIEW

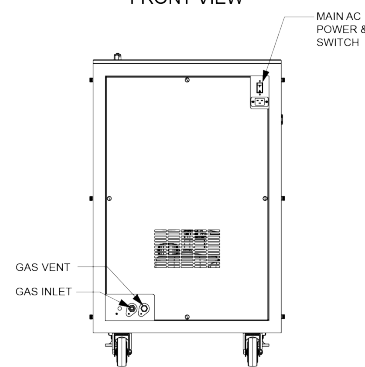

REAR VIEW

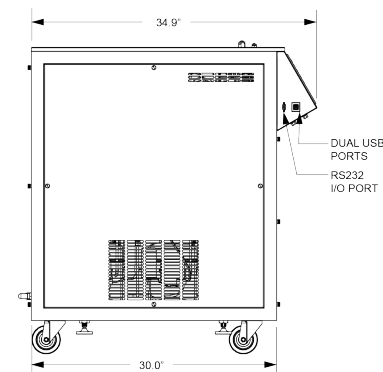

LEFT VIEW

For More Information or to Place an Order Contact:

Thunder Scientific®

623 Wyoming Blvd. SE • Albuquerque, New Mexico 87123-3198
 Ordering: 800.872.7728 • Tel: 505.265.8701 • FAX: 505.266.6203

www.thunderscientific.com